

This series is a rigid-type coupling that connects a ball screw and servo motor, or one shaft to another shaft. Be aware that it does not permit center deviation or a deflection angle between the 2 shafts. The shaft tolerances, surface roughness, and correct tightening of the lock bolts are very important factors in order to obtain the designated performance. If you have any questions, please contact a dealer or our company.

For safe use of the product

Thank you for your purchase of an ISEL product. In order to use the product safely and obtain the designated full performance, please be sure to read the following items.

- Read this instruction manual carefully and understand the contents before using the product, and be sure to observe all instructions in the manual and use the product correctly.
- Be sure that you fully understand the information related to the device and safety before using the product.
- After reading, be sure to store this manual carefully so that it can be referred to at any time when needed during use.

This manual classifies important precautions into two categories: DANGER and WARNING.

⚠ DANGER	⚠ WARNING
<p>Incorrect use or handling will produce dangerous conditions that may result in death or serious injury.</p>	<p>Incorrect use or handling will produce dangerous conditions that may result in injury. There is also the risk of property damage.</p>

⚠ DANGER

- ◆ When using this product, be sure that the necessary mechanisms (covers, enclosures, etc.) for ensuring the safety of life and health are installed on the equipment.
- ◆ Wear clothing and protective gear that is suitable for the work.
- ◆ Keep the work area clean and orderly, and work safely in order to prevent secondary accidents.
- ◆ In the environment where the product operates, install safety mechanisms onto all parts which may be a danger to the operator.
- ◆ When performing maintenance or inspections, turn OFF the motor power (power supply) and check that the machine has fully stopped before beginning work.
- ◆ Before using lift equipment, install safety measures on the equipment to prevent falling. There is the risk of death or injury, as well as damage to the equipment, if the lift part falls.
- ◆ If the product is used for transporting persons, install the necessary equipment for safety.
- ◆ Do not touch the product while it is operating. Doing so may result in injury, damage to the product, or other damage.
- ◆ Do not use the product for any purpose other than the designated purpose, and do not modify the product. There is the risk that the designated accuracy and performance will not be possible.
- ◆ If abnormal noise or vibration occurs during work, immediately discontinue operation and inspect the equipment and this product. If use is continued without inspecting, there is the risk of injury to operators, damage to equipment, and other damage.

⚠ WARNING

- ◇ Check that the product is the one you ordered and that there is no damage to it. If the product is not the one you ordered or is damaged, there is the risk of injury to operators, damage to equipment, and other damage.
- ◇ Never use molybdenum oil or oil which contains an extreme-pressure additive. Doing so may cause a large decrease in allowable torque, resulting in slipping.
- ◇ If the shaft includes a key groove, it can be used as long as the groove width is as prescribed in the JIS standard. However the maximum allowable torque is reduced by 15% - 20%. Remove any burrs on the key groove before using.

- ◇ If the product is reused, check that there is no deformation, damage, or other problem with the product or any of its components before use. If there is damage, deformation, or other problem, replace with a new product.
- ◇ When tightening lock bolts, be sure to use a torque wrench that includes a torque adjustment scale, and tighten at the designated tightening torque. Use of a plate-type torque wrench may cause slipping, deformation, and other trouble because it is difficult to check the designated torque.
- ◇ Never use any bolt other than the designated bolt. There is the risk of damage to the bolt, resulting in an accident.
- ◇ In order to ensure the designated performance, an opposite shaft with tolerance grade h7 and surface roughness of Ra1.6 or less is recommended.
- ◇ In the case of a hollow shaft (pipe), depending on the thickness it may not be possible to obtain sufficient surface pressure. Please contact our company.
- ◇ If the product has special specifications, it may differ in parts from the contents of this instruction manual. Please contact a dealer or our company.
- ◇ If the bolts are tightened when the coupling is not connected to anything, the coupling may become deformed and be rendered unusable. Therefore check that the shaft is fully inserted into the coupling when tightening the bolts.

● Structural drawings

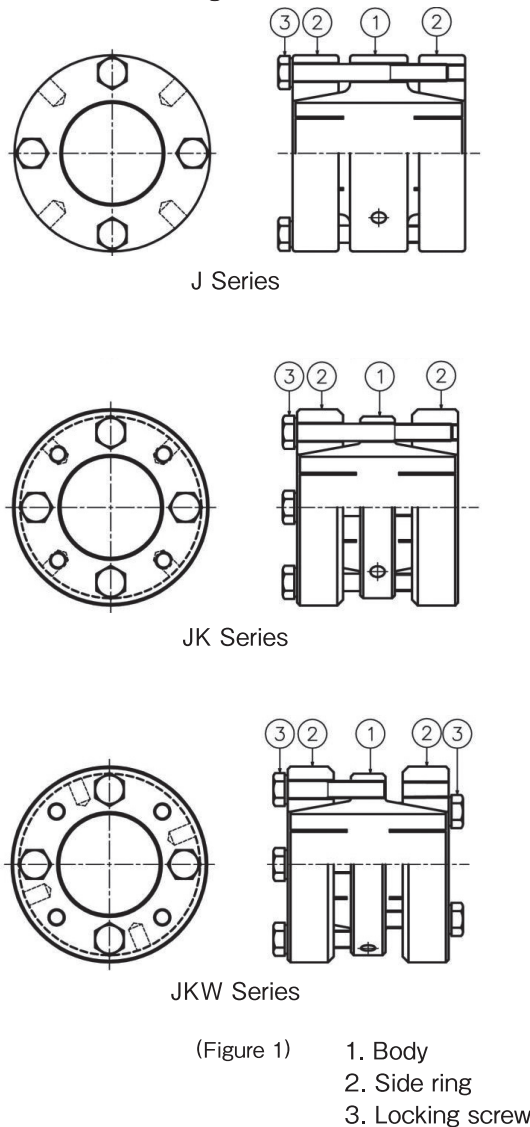

(Figure 1) 1. Body
2. Side ring
3. Locking screw

● Installation

- (1) Use paint thinner or other means to wipe off any corrosion, dirt, or other substance from the surface of the shaft, then apply a light coat of oil.
- (2) Apply a light coat of oil to the coupling inner diameter parts, contact parts of each taper, and the threads and head seats of the lock bolts.

⚠ WARNING

- ◇ Using the product after unpackaging without applying oil to it may cause a decrease in allowable torque.
- (3) Because this coupling is a rigid coupling, be sure to

machine the edge of the servo motor mounting flange (a), casing (b), and ball screw-side bearing parts (c) and (d) at the same time to ensure accuracy. (Concentricity, perpendicularity, parallelness) (Figure 2)

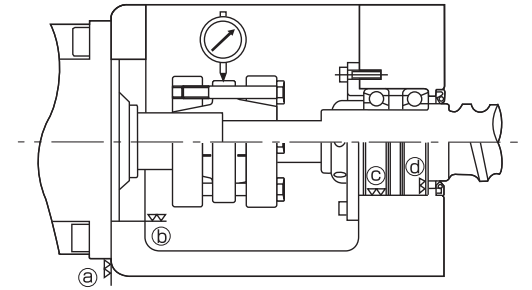

(Figure 2)

- (4) Install the coupling onto the servo motor shaft and insert the motor into the casing. Install the coupling onto the ball screw shaft. After positioning, fasten in place with the body holding hole and tighten the lock bolts. (The JKW Series has lock bolts on both sides, and can be fastened onto the shaft on either side.) Use a torque wrench and tighten the lock bolts at diagonally opposite positions in sequence. Tighten gently at first (approximately 1/4 of the designated torque) then gradually increase the tightening force (approximately 1/2 of the designated torque), and then fully tighten the bolts at the designated torque. (Figure 3) (Table 1) At this time, place a dial gauge onto the coupling body outer diameter. Rotate the coupling by hand and tighten the bolt until the gauge runout is close to zero. Finally repeat tightening of each bolt several times, working in the peripheral direction. Check that all lock bolts have been tightened at the designated torque and that there is little runout. Also check that no lock bolts were skipped during tightening.

Strength category 10.9 or higher	
Bolt	Tightening torque N·m
M5	8.8
M6	17.7

(Figure 3) (Table 1)

● Removal

- Check for safety before beginning removal work.
- (1) Turn OFF the motor power (power supply) and check that there is no torque or thrust force applied to the coupling, and that there is no risk of falling or other accident.
 - (2) Fasten the body using the holding hole, and gradually loosen each of the lock bolts in sequence. (If the lock bolts are loosened all at once, the coupling may disengage instantly. This is dangerous. Use caution.)
- ◇ Although this product is designed with a taper angle for natural separation, if it is stuck or cannot be removed for another reason, use a flathead screwdriver or similar tool to pry gently between the body and side ring. When prying, keep the screwdriver away from tap holes and drilled holes, and try as much as possible to avoid causing scratches.

*Specifications may be changed without notice.

ISEL CO., LTD. ☎ 0120-86-6351

Head Office	1-2-16, Atobe-Kitano-Cho, Yao City, Osaka 581-0068, Japan TEL: 072-991-0450 FAX: 072-994-7593
Hiroshima Factory	6, Shinfukushiro, Tojo-Cho, Shobara City, Hiroshima 729-5112, Japan TEL: 08477-2-3699 FAX: 08477-2-3314
East Japan Office	5-55, Omano-Cho, Koshigaya City, Saitama 343-0844, Japan TEL: 048-986-6351 FAX: 048-986-6361
Nagoya Office	Fuji Jingu Bldg. 303, 1-11-6, Yokota, Atsuta-Ku, Nagoya City, Aichi 456-0022, Japan TEL: 052-681-0420 FAX: 052-681-0430